

## Research on Linking between Bridges and Existing Road Network of Mountainous City

Xiaoxia Zhai<sup>1</sup>, Lin Wu<sup>1</sup>

Chongqing Jiaotong University, China

Correspondence: Room 105, Unit 2, Building 12, Knowledge Garden Community, Chongqing Jiaotong University, China.

### Abstract

Because of the complex topography of mountainous city, there is usually large difference between bridge and existing road network in elevation. In order to realize rapid traffic of vehicles, reasonable interchange ramp can be designed to realize rapid dividing of vehicles at bridgehead. This paper mainly introduces a typical interchange at bridgehead — Caiyuanba Interchange, located in Chongqing, a mountainous city, explains difficulties encountered in engineering design and realizes rapid dividing of vehicles by designing reasonable interchange at bridgehead, so as to accumulate certain experience in the construction of interchange at bridgehead.

**Keywords:** Mountainous city, elevation, existing road network, interchange at bridgehead, rapid traffic

### I. Geographical Complexity of Caiyuanba Interchange



Picture 1 Caiyuanba Interchange

Caiyuanba Interchange locates outside Caiyuanba railway station square and connects with the original interchange; there are many buildings under and above the ground and pipes under the ground; moreover, the traffic is quite busy; as a result, it's difficult to design the interchange horizontally and vertically. The main difficulties are as follows:

- (1) The place where the interchange locates is narrow. There are many buildings around it and it is also limited by the original interchange. Therefore, the land area that can be effectively used for the interchange is quite small, creating a narrow geographical space.
- (2) Caiyuanba area is a transportation hub section, so its traffic volume is extremely large. During conception of the interchange scheme, not only should the traffic volume of existing road be considered, but also designers shall take into account that in the future. The construction of the new interchange was conducted on the basis of the original interchange, so attention should also be paid to the interference of existing interchange.
- (3) The interchange is located in the central section of Chongqing main urban zone, next to the railway station and Chongqing Long-distance Coach Station. It is a collection and distribution center for people and logistics in Chongqing City and Yuzhong District. In this section, the main urban arterial streets, for example Zhongshan No.3 Road, Nanqu Road, Changbin Road and Caiyuan Road, are intricate. It is a transportation hub of the main urban zone of Chongqing City and a window to the outside world. Therefore, there are a great number of people and vehicles gathered and distributed.

It can be said that the underground mall is grand in scale and its orientation, profile and beam column are quite complicated. According to field survey, the underground grotto comprises over three storeys, so this giant underground facility can cause great impact onto the ramp setting.

- (4) The underground pipe network at this place is

quite complex. In addition to regular communication, electricity, rain and sewage pipes, there are also, among other things, drain pipes and postal channels of main urban zone with the diameters of several meters and some drain pipes are buried as deep as over 20 meters.

- (5) Since there are many buildings in the place where the interchange locates, span and beam of ramp bridge are restricted in height.
- (6) The interchange shall be arranged to the extent of benefiting the arrangement of track line no.3 in space and by taking into account of the transfer between rail traffic and bus transport.

## **II. Difficulties in the Design of Caiyuanba Interchange**

Due to the particularity of the geographical location of Caiyuanba Interchange, many difficulties (as listed below) can be encountered in its design. Therefore, during plan proposal, these difficulties must be overcome:

- ① Existing interchange ramp and intersecting roads in this region are intricate and complex. There are two road (Nanqu Road and Changbin Road), 3 levels and 6 crossings, which makes it difficult to set the new interchange ramp as overpass type. At the same time, because of great elevation difference between existing road network and the bridge, it's necessary to increase the layers of the interchange to solve this problem. So, in interchange design, it can reach up to 5 layers (inclusive of light rail transport), which would cause certain impact upon horizontal and longitudinal design of ramp.
- ② Complex municipal engineering projects such as underground shopping mall, civil air defense facilities and various pipe networks in the place where the interchange locates would make the overpass difficult to meet the requirements. What's worse, these engineering projects greatly limit plan design and span layout of the ramp and produce higher requirements on ramp alignment design.

- ③ Bund shopping mall can be seen on the right of the interchange and need to be reserved due to certain causes. Thus, design scheme of the interchange would be affected to some extent. The space between bund shopping mall and the high-rise building to its east is only 18m, but the density of buildings is relatively high. Under the condition of reducing the impact of the interchange upon it, it's very difficult to set the ramp.
- ④ The ramp has to pass through the main line at many positions downwards, so its alignment design will be limited by arrangement and elevation of bridge approach. Ramp will be greatly limited in alignment design.
- ⑤ Caiyuanba Yangtze Bridge functions for two

purposes, road traffic and rail traffic. Rail line no.3 and ramp are crossed for multiple times and the longitudinal slope shall be arranged to the extent of reserving enough space for rail traffic.

### III. Schematic Design of Caiyuanba Interchange

To overcome various difficulties in design, 8 proposals were made during the preliminary design stage. Of the 8 proposals, 4 representative proposals were picked out for analysis, comparison and selection. Finally, a multi-layer semi-directional partial interchange proposal was determined.



Picture 2 Caiyuanba Multi-layer Semi-directional Partial Interchange

The interchange proposal gives full consideration to existing interchange ramp, existing roads, buildings and influences of other factors, and reasonably makes use of its topographic conditions. Its main features are:

- ① Small in land occupation and demolition & relocation quantity, without affecting the bund mall;
- ② Clear traffic direction, favorable linear

indicators, minimum radius 60 m, and relatively higher service level;

- ③ Railway square and Coral Park are retained completed, which would benefit urban landscape and image;
- ④ Changbin Road and Caiyuan Road are directly connected together and this solves problems left over by history.

According to the interchange proposal, there are

7 ramps connected to the bridge for dividing vehicles driving on or off the bridge. They are:

- ① A ramp starting from Xiangyang Tunnel, passing by Shancheng Hotel, to the main bridge of Caiyuanba Yangtze Bridge;
- ② A ramp starting from Caiyuan Road to the main bridge of Caiyuanba Yangtze Bridge;
- ③ A ramp starting from Nanqu Road through ramp to the main bridge of Caiyuanba Yangtze Bridge;
- ④ A ramp starting from Lianglukou Escalator to the main bridge of Caiyuanba Yangtze Bridge;
- ⑤ A ramp starting from the main bridge of Caiyuanba Yangtze Bridge to Zhongshan No.3 Road Power Company at Lianglukou;
- ⑥ A ramp starting from the main bridge of Caiyuanba Yangtze Bridge to Caiyuanba underground passage, to Jinyan Hotel, then to Bayi Tunnel;
- ⑦ A ramp starting from the main bridge of Caiyuanba Yangtze Bridge to Changbin Road.

Five ramps on the ground that are not directly connected to the bridge can meet the demands of

vehicles going to the five intersections, Xiangyang Tunnel, Caiyuan Road, Changbin Road, Nanqu Road and Caiyuanba Yangtze Bridge. These five ramps are:

- ① A ramp starting from Caiyuan Road to Changbin Road;
- ② A ramp starting from Changbin Road to Nanqu Road;
- ③ A ramp starting from Xiangyang Tunnel, to Caiyuanba roundabout, then to Caiyuan Road or Nanqu Road;
- ④ Ground ramp and ramp bridge starting from Caiyuan Road to Nanqu Road.

Vehicles driving from Tongyuanju to Lianglukou, Shangqingsi or other places can be divided through Caiyuanba Bridge, other than through Shibampo Yangtze Bridge, and drive off “Y” type ramp of Lianglukou Zhongshan No.3 Road, finally shortening vehicles’ traffic time.



Picture 3 Multi-layer Semi-directional Partial Interchange

#### IV. Structural Design of Caiyuanba Interchange

The interchange is set with seven ramp bridges

to connect to the bridge and the total length of ramps is 2,007.9 m. Two pedestrian bridges are set, 1 pedestrian passageway is added, 4 pedestrian

passageways are reconstructed, 2 existing structures are renovated and 15 retaining walls added. Since the span of ramp bridge is limited by geographical condition, bridge pier shall be arranged to try to avoid underground pipeline and underground structure; the span of the overall interchange falls between 25 m and 40 m.

The substructure of ramp is divided into two

zones according to present situation, i.e., original interchange zone and newly built interchange zone. In original interchange zone, in order to coordinate the substructure with original interchange pier, cylinder pier (diameter 150 cm) is adopted at outside zone of bund. Meanwhile, pier is of vase type pier to ensure its consistency with main bridge approach in type.



Picture 4 Pier of Original Caiyuanba Interchange

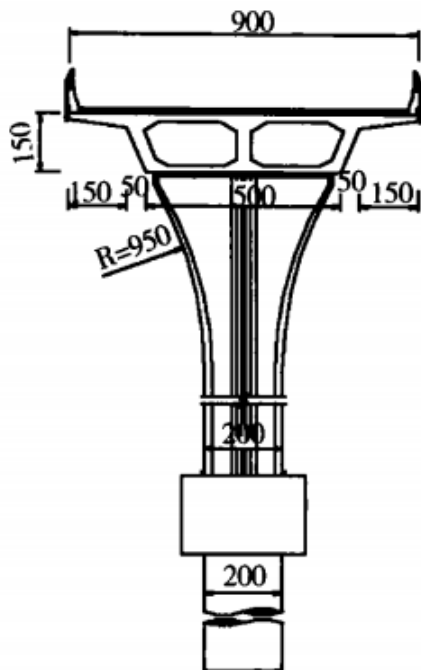

Picture 5 Vase Type Pier of New Caiyuanba Interchange

## V. Structural Features of Caiyuanba Interchange

Around Caiyuanba Interchange, there are Binjiang Road in the south, Coral Park in the east, Railway Square in the west and mountains in the north; besides, Bund Square is next to Coral Park. Therefore, surrounding topography is quite complicated. Problems such as large difference between Caiyuanba Bridge and existing road network in elevation, and direction of light rail line no.3 going across the river by the bridge constitute difficulties of designing Caiyuanba Interchange and at the same time, these are innovation points in structural design.

- ① Because of the control of underground structure, pipeline and clearance, bridge structure of Caiyuanba Interchange is limited. The span of the main beam of the interchange reaches up to 40 m, depth-span ratio reaches 1/26.7 and technical parameters are leading in comparison with that of similar bridges. Therefore,

superstructure of Caiyuanba Interchange is structured with prestressed concrete box girder and constructed with span-by-span cast-in-place floor support.

- ② Caiyuanba Interchange is the combination of new and old interchanges. At Lianglukou, vehicles coming from Bayi Tunnel can drive along connection ramp of the artery, then Caiyuanba Yangtze Bridge and reach South Bank Region, while original interchange ramp

can keep vehicles driving along Nanqu Road. Vehicles driving on Changbin Road can drive along interchange ramp, then Caiyuanba Yangtze Bridge to reach South Bank Region rapidly. These newly built interchange ramps are designed reasonably to reserve original interchange and effectively develop the traffic functions of new and old interchanges, thus dividing vehicles here.



**Picture 6 Original Caiyuanba Interchange**



**Picture 7 New Caiyuanba Interchange**

- ③ The interchange is closely integrated with urban environment in form and keeps harmonious with surrounding environment and landscape. As to interchange pier, in existing interchange where

ramp is lower and buildings are higher, existing interchange adopts cylinder piers; as a result, new interchange adopts cylinder piers as well; however, for bund mall, due to large difference

between existing road network and bridge in elevation, ramp bridge adopts vase type high pier, which not only meets the demands for basic traffic capacity of the interchange, but also coordinates with urban landscape.

- ④ Diversity of traffic function. Light rail line no. 3 crosses the river by Caiyuanba Yangtze Bridge and connects to tunnel through Caiyuanba interchange ramp; pedestrians can reach either railway station through Huangguan Escalator or other places including Zhongshan Branch Road through other exits. Proper setting of interchange ramp guarantees that traffic of light rail line no.3 will not affect vehicles of other ramps and its setting separates pedestrians.

## VI. Conclusion

In a mountainous city, mountains, rivers and fluctuant topography are complicated in geographical conditions. Due to impacts of nature of and task about approach alignment, bridge deck elevation, river bank slope, main river, branch trough hydrology and crossing road network, it's completed in linking bridge and existing road network. By studying the connection between bridge and existing road network in a mountainous city and summarizing some useful experiences, this paper will provide reference for relevant design in the future.

## References

- [1] Jiasi Sun (1999). Road Interchange Planning and Design. Beijing. People's Traffic Press [M], 2009.
- [2] Shuanhai He et al. Road Interchange Planning and Design. Beijing. People's Traffic Press [M], 2009.
- [3] Qing Sun, Jiasi Sun et al. Characteristic and Functional Analysis of Interchange at bridgehead. Technology of Highway and Transport [J], 2005(2): 3-5
- [4] Baojing Zhu, Yangyang Yu et al. Analysis Based on the Present Situation of Chongqing Caiyuanba Interchange Engineering. Technology of Highway and Transport [J], 2011(189): 20-22
- [5] Yun Zou, Ming Li et al. Design Proposal of Caiyuanba Interchange of Chongqing Caiyuanba Bridge Engineering. Journal of Chongqing Jiaotong University [N], 2004(5): 1-4
- [6] Qiang Luo, Yun Zou, Tao Li, Ming Li et al. Design Features and Key Technologies of Chongqing Caiyuanba Yangtze Bridge Interchange Project. Technology of Highway and Transport [J], 2005(Z): 19-22
- [7] Ming Li, Yun Zou et al. Design of Sujiaba Interchange of Chongqing Caiyuanba Yangtze Bridge. Technology of Highway and Transport [J], 2004(4): 47-49
- [8] Tianming Zhang, Qiong Zhong et al. Comparison and Selection among Proposals of Light Rail Crossing River by Chongqing Yudong Yangtze Bridge. Technology of Highway and Transport [J], 2011(5): 70-72
- [9] Weicheng Wei, Zou Yun et al. Discussion on Design Proposal of the Interchange at South Bridgehead of Chongqing Yudong Yangtze Bridge. Technology of Highway and Transport [J], 2010(5): 29-31
- [10] Jing Zhang. Introduction to Chongqing Jiahua Bridge. Technology of Highway and Transport [J], 2009(5): 153-155
- [11] Jun Tan, Jiasi Sun, Haiyan Jia. Analysis of Aesthetics Factors of Urban Interchange. Technology of Highway and Transport [J], 2009(5): 153-155
- [12] Enya Yu, Jiasi Sun. Preliminary Exploration of Urban Interchange. Journal of Chongqing Jiaotong University. [N], 2006(6): 46-50
- [13] Maohua Yang. Research and Discussion of Urban Road Traffic Planning and Design. Architectural Design [J], 2010(6): 13-14

- [14] Peng Zhang. Analysis and Comparison among Common Forms of Interchanges. *Traffic World [J]*, 2007(4): 104-105
- [15] Yong Wang. Engineering Design of Chongqing Huacun Interchange. *Road Traffic [J]*, 2007(1): 12-15
- [16] Yaping Lai, Chun Yang, Guolei Ren et al. Design of Ramp of Fuling Wujiang No.2 Bridge. *Bridgehead Construction [J]*, 2004(4): 47-50
- [17] Hanxin Chen, Chi Luo et al. Design of Chongqing Huanghuayuan Interchange. *Urban Road Bridges & Flood Control [J]*, 2007(1): 17-20